



www.AKCP.com

ropeWater Sensor



Copyright © 2014, AKCess Pro Co., Ltd..

Table of contents

1. Introduction
2. Features
3. Configuring the ropeWater sensor
4. Configuring the ropeWater sensor on a sensorProbe unit
5. Configuring the ropeWater sensor on a securityProbe or a securityProbe 5E unit
6. Detection of Acid
7. Mounting the ropeWater sensor impedance setting & trouble shooting

Introduction

Water can enter a building in many different ways and, in some cases, remain undetected. This can cause damage and problems to sensitive electronic equipment. Computer and mainframe rooms which have a false floor and ceilings could harbor undetected water, which is only detected after a problem occurs.

The ropeWater sensor is capable of detecting the presence of or non-presence of water. It contains a microprocessor controlled capacitance measuring circuit which is far more precise than commercially available standard water detectors which measure the resistance of water.

The detector provides feedback to the web based interface which will indicate the presence/absence of water with a Normal/Alert, or Critical indication. The unit will retain any error condition until it is read via a *snmpget*. Therefore, if it encounters a critical condition at any time, it will report that condition before it returns to a normal state.

The value of the status for the SNMP OID for the ropeWater sensor can be Normal, No Status, Critical or Sensor Error.

ropeWater sensor OID:

For a switch type sensor on RJ45#1 the OID for the status is **.1.3.6.1.4.1.3854.1.2.2.1.18.1.3.0**

Features:

- On/Off alarm signal of Water detected
- Accurate, cost effective Water detecting system
- Rope portion of the sensor is submersible
- Sensor type - open/closed contact switch
- Power source: powered by the unit. No additional power needed.
- Power Consumption: Typical 125 mWatt, 25 mA
- The unit auto detects the presence of the ropeWater sensor
- Up to 2 ropeWater sensors per unit sensorProbe2.

- Up to 8 ropeWater sensors per unit sensorProbe8.
- Hundreds of ropeWater sensors per securityProbe 5E and E-sensor8 E-modules
- Full Autosense including disconnect alarm if cut, broken, or disconnected
- Sensing rope cable can be pre-ordered from a 10 foot minimum to any custom run length of up to 165 feet or 50 meters.
- Non-sensing cable comes in a standard 20 foot run length.
- Can be connected to any of the sensorProbe or securityProbe's 8 RJ-45 Intelligent sensor ports or any of the securityProbe 5E's E-sensor8 expansion module ports.
- Can be extended up to 100 feet, or 30 meters using normal CAT5\6 LAN cable from the RJ-45 sensor ports.
- Measurement range: Wet or Dry (-20 degrees C- +60 degrees C)
- Comes fully assembled and includes the rope portion that is the water sensing cable, the non-sensing area cable (from the rope to the sensing module) and the main sensing module.

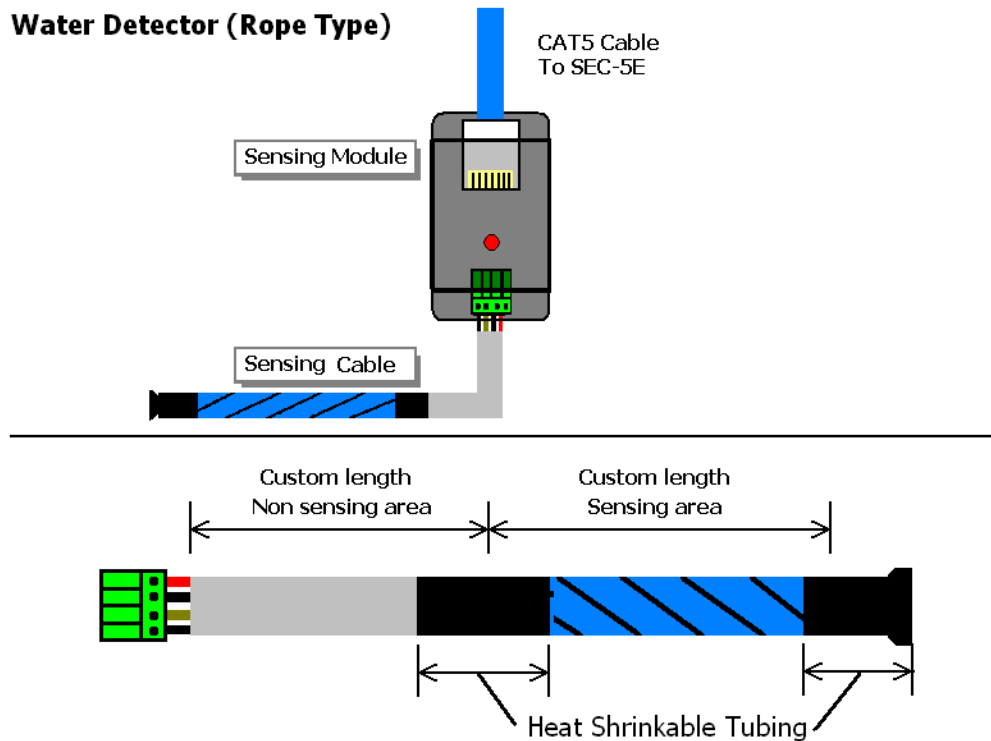

ropeWater sensor product assembly diagram

Configuring the ropeWater sensor

- a) Plug the sensor into one of the RJ45 ports on the rear panel of the unit or expansion module.

- b) Now point your browser to the IP address of the unit (default, 192.168.0.100). Next you need to login as the administrator using your administrator password (default is “public”). You will then be taken to the summary page.
- c) From the summary page you need to select the sensors tab. The layout of the next page will vary depending on your unit so please refer to your unit’s manual.
- d) You should now be able to setup the thresholds for your sensor. The low critical, low warnings, normal, high warnings, high critical values can be set from this page.

Now we will cover the settings that are specific to your sensor.

Status: If the sensor is offline, the status is No Status. If the sensor is online, and there is no water detected, the status is Normal. If water is detected, then the status is Critical. If at any time communications with the ropeWater sensor are lost, the status of the ropeWater sensor is changed to Sensor Error.

Configuring the ropeWater sensor on a sensorProbe unit

The ropeWater sensor shows the “Normal” status in Summary page after connecting the sensor.

Port	Type	Description	Reading	Status
1	-	-	-	-
2	-	-	-	-
3	-	-	-	-
4	-	-	-	-
5	Humidity	Humidity5 Description	35 %	Normal
6	Temperature	Temperature5 Description	82 °F	Warning
7	-	-	-	-
8	Water	AKCP ropeWater Sensor Demo	-	Normal

Use the Sensors page and the Water Detector sensor settings in the sensorProbes web interface for configuring the ropeWater sensors settings.

The ropeWater sensor shows the “Critical” status in the Summary page after detecting water.

Port	Type	Description	Reading	Status
1	-	-	-	-
2	-	-	-	-
3	-	-	-	-
4	-	-	-	-
5	Humidity	Humidity5 Description	36 %	Normal
6	Temperature	Temperature5 Description	81 °F	Warning
7	-	-	-	-
8	Water	AKCP ropeWater Sensor Demo	-	Critical

Configuring the RopeWater sensor on a securityProbe or a securityProbe 5E unit

The ropeWater sensor shows the “Normal” status in Summery page after connecting the sensor and when water is detected is will show “Critical” in this page and the syslog:

The screenshot shows the 'Sensors' page of the securityProbe web interface. The 'Sensor Information' table lists various sensors, with the 'ropeWater Sensor' highlighted in red and its status set to 'Normal'. Below the table, the 'System Log' shows a sequence of messages, with the entry 'ropeWater Sensor status is Critical' circled in red.

Board Name	Type	Sensor Name	Reading	Status
E.opto16 – 16 opto isolated dry contacts 1	Board	E.opto16 – 16 opto isolated dry contacts 1	-	Normal
E.opto16 – 16 opto isolated dry contacts 2	Board	E.opto16 – 16 opto isolated dry contacts 2	-	Connected
E-sensor8 – 8 intelligent E-Module	Thermocouple	Thermocouple Demo on E.module	74.8 °F	Normal
	Dry contact I/O	Smoke Detector Sensor In Demo Rack	-	Normal
	Humidity	Humidity Port 4 on E-sensor8 – 8 intelligent E-Module	40 %	Low Warning
	Dual Temperature	Temperature Port 4 on E-sensor8 – 8 intelligent E-Module	25.9 °C	Normal
	Relay	Relay Port 6 on E-sensor8 – 8 intelligent E-Module	-	Sensor Error
	Water	ropeWater Sensor	-	Normal
Internal RJ45	Board	Internal RJ45	-	Sensor Error

Msg No	Time	Message
71	2000/05/20 14:29:40	Sound Detector status is Normal
72	2000/05/20 14:29:39	Sound Detector status is Low Warning
73	2000/05/20 14:29:38	Sound Detector status is Normal
74	2000/05/20 14:29:38	Sound Detector status is Low Warning
75	2000/05/20 14:29:37	ropeWater Sensor status is Normal
76	2000/05/20 14:29:37	ropeWater Sensor status is Critical
77	2000/05/20 14:29:37	Sound Detector status is Normal
78	2000/05/20 14:29:37	Sound Detector status is Low Warning
79	2000/05/20 14:29:35	Sound Detector status is Normal
80	2000/05/20 14:29:35	Sound Detector status is Low Warning

Use the Sensors page and the Water Detector sensor settings in the sensorProbes web interface for configuring the ropeWater sensors settings.

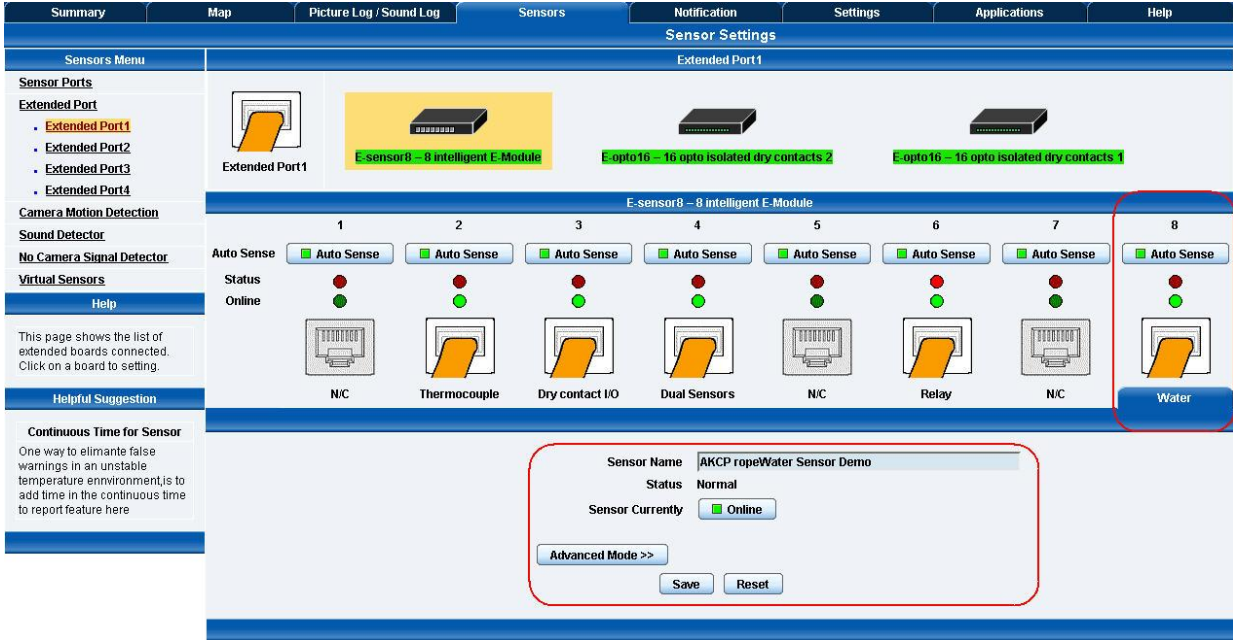

Detection of Acid

In power monitoring situations where backup battery and UPS are used to ensure a constant power supply there is a risk of battery's leaking harmful battery acid. Use this rope sensor underneath backup battery banks to give advanced warning of battery acid leaks.

Note: This product is designed for short term exposure to battery acid only. Tested with 40% concentrate Sulphuric acid (H2SO4)

Mounting the ropeWater sensor

We recommend using any standard plastic U-clip or half U-clip with the adhesive base as shown in these two pictures below. These types of clips can normally be found at your local hardware store.

When installing or handling your new rope sensor, please be sure to handle the rope portion of the sensor with care, avoiding any twisting, excessive bending or putting stress on the rope, as the internal sensing wires are very delicate and can become damaged quite easily.

UC
U-Clip with Adhesive Base

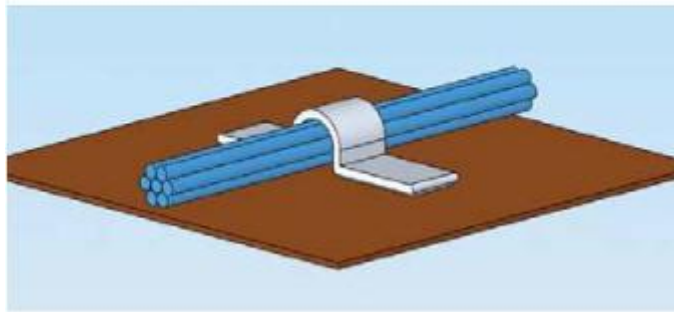

HUC
Half U-Clip with Adhesive Base

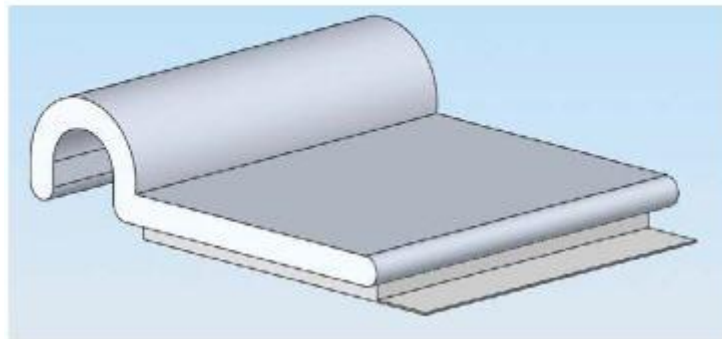

Notes on sensitivity and status changes

Keep in mind the rope water sensors “wet” to “dry” status change (critical condition to normal condition) can take up to 30 minutes after the sensor has been in contact or submerged in water, even when the rope is wiped dry as there could still be water present within the inner windings of the rope cable.

Also, this is due to high sensitivity of the rope. The sensor modules internal computation and update to the base unit's web interface also has a factor in the time it takes to update the sensor status from the “wet” or critical condition back to the “normal” or non-critical condition.

Trouble Shooting the ropeWater sensor

The rope type sensors are sensitive to EMI and also metallic or conductive items and surfaces.

So they **should not be installed** on a metal floor for example. They also should not be installed where they will be in direct contact with metal piping or installed near power equipment.

We highly suggest you first test the rope water sensors before they are installed to ensure that they work when removed from the packaging.

If you receive sensor errors in the web interface of the unit when first connecting the sensors here are some steps to take:

1. Check the 4 wires which are screwed to the Green terminal block. See below picture. Sometimes these can become loose during shipment.

2. Check the tail connector contacts if they are not damaged. After checking, reconnect them together as shown in the picture below.

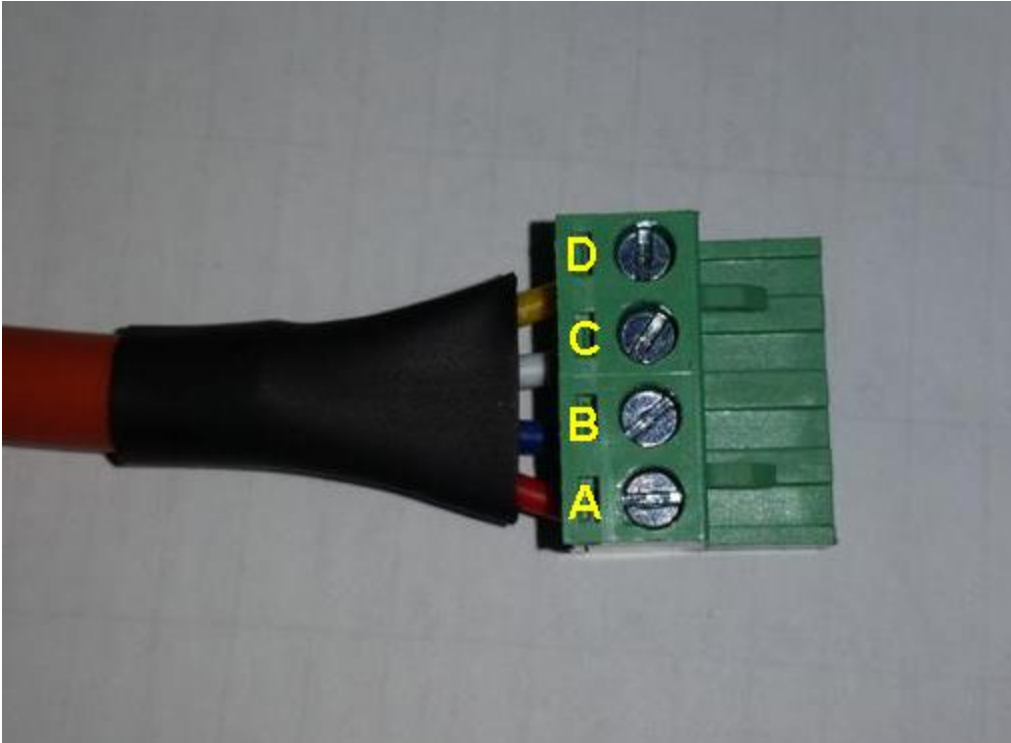



3. Continuity Test. Referring to the picture of the connector above. Disconnect the module from the green terminal block then using a multimeter:

- A. Measure the resistance between A-B.
- B. Measure the resistance between A-C.
- C. Measure the resistance between A-D.
- D. Measure the resistance between B-C.
- E. Measure the resistance between B-D.
- F. Measure the resistance between C-D

Recheck A-B with a multimeter. The value should be near C-D. A-B should not be infinite otherwise it will return a sensor error. Please send these testing results to support@akcp.com and include the length of the rope and the serial # which is located on the side of the black electronics module.

Notes on the Impedance and Sensitivity of the ropeWater Sensors

The rope sensors come with the impedance value in the package. If they don't have this then this is how it is calculated:

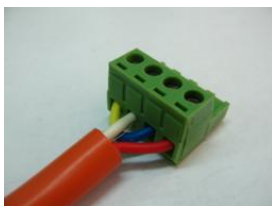

Regarding the sensing impedance, please find below the instruction to calculate it for more custom value.

Sensing Impedance = [(Rope resistance between pin 1 and 2 + Rope resistance between pin 3 and 4) / 2] / Water Rope length in meter

Pin 1 is the red wire on the green phoenix connector and pin 4 is the yellow wire.

The sensitivity of the sensors is not adjustable. All sensors are tested before shipment using a damp sponge.

There's no point changing the sensing impedance value for the RWS on the web interface. Although we do measure the individual resistance of each wire to compute the impedance value of the rope during our production process & testing prior to shipment, it is done to make sure that the impedance is within the module's acceptable working range. For the Locate ropeWater Sensors, the value is printed on a sticker which goes to the tail connector and to a quick start guide for setting it up on the web UI.

In a good operational RWS the connections should be well intact and the status should be showing Normal in the web UI. You can test this by disconnecting the Green terminal block from the module (black box). The Red LED of the module should turn on and the status should change to critical. Plug the Green terminal block back in place then wait for the Red LED to turn off. Then wet the yellow or blue cable with water not the Orange cable.

Notes on the Rope Types of the ropeWater Sensors

We changed to a new supplier of the rope in 2012 which is of better quality than the previous rope type we used.



Please see the picture above that shows the two different rope types. The blue colored rope is the previous rope type we used. The product codes were RWSTXX (sensor), RWSTCABXX (extensions), LRWSTXX and LRWSTCABXX.

The new rope type sensors product codes are now RWSCXX, RWSCCABXX, LRWSCXX and LRWSCCABXX. This is the yellow colored rope in the picture attached.

Our production manager has confirmed that both types of rope water sensor extensions (RWSTCABXX and RWSCCABXX) are compatible and nothing else changed on the sensor, just the rope type.

This concludes the AKCP ropeWater Manual.

Please contact support@akcp.com if you have any further technical questions or problems setting up your modem or your alerts.

Thanks for Choosing AKCP!